

**Important:** If you are not a trained motorcycle mechanic stop now. Ask a local motorcycle shop to do the work for you.

**Please take extra care!**

You have to mount the crash-pads one side after the other! Do not loose more then one engine mounting bolt at the same time!

The tightening torques refer to the manufacturer's instructions!

**Fitting on the right side**

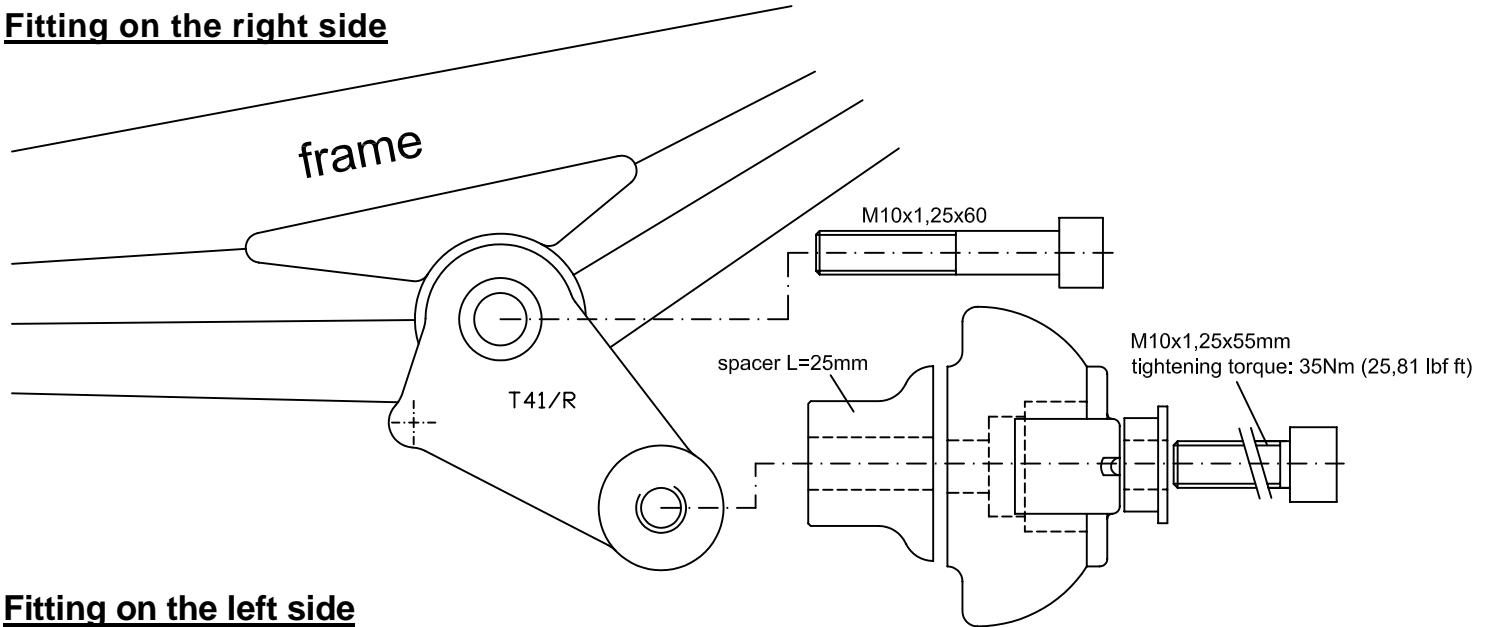

**Fitting on the left side**

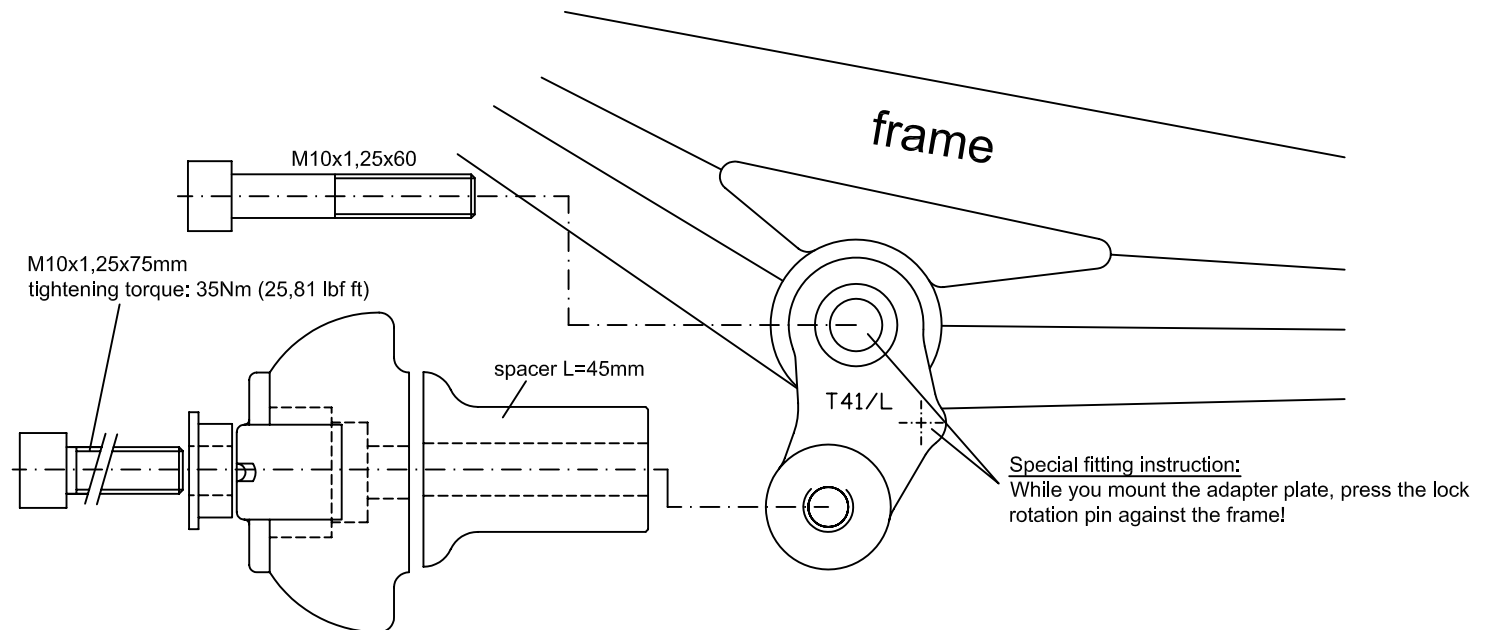

**Special fitting instruction:**  
While you mount the adapter plate, press the lock rotation pin against the frame!

