

Important: If you are not a trained motorcycle mechanic stop now. Ask a local motorcycle shop to do the work for you.

Please take extra care!

You have to mount the crash-pads one side after the other! Do not loose more then one engine mounting bolt at the same time!

The tightening torques refer to the manufacturer's instructions!

The cowling has to be modified, use the drilling template!

Fitting of the right side:

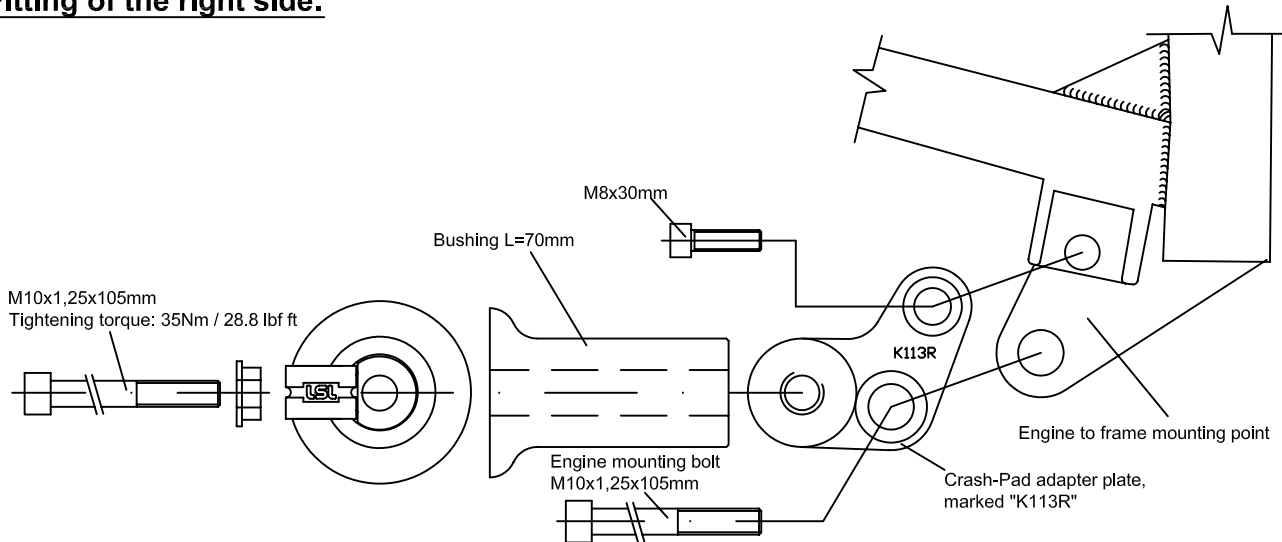

Fitting of the left side:

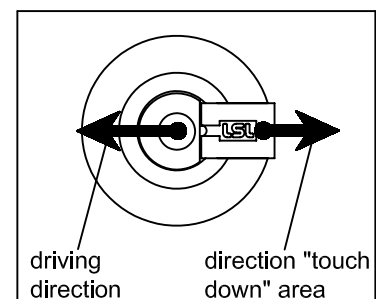
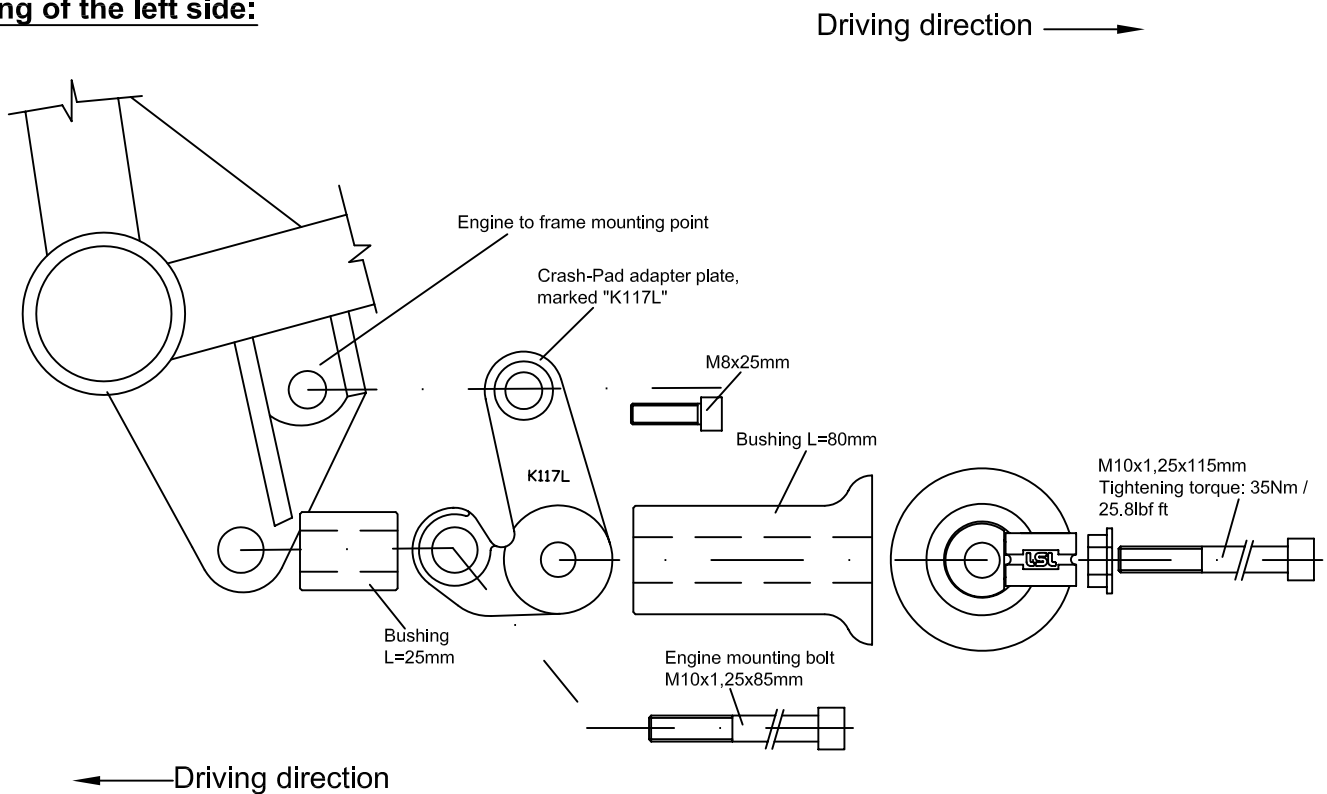

LSL-Motorradtechnik GmbH • D-47809 Krefeld

www.lsl-motorradtechnik.de

Stand: 13.12.2006

Drilling template for Crash- Pads Kawasaki ER-6F 2006 → Art.Nr.: 550K117

Attention: Mark both fairing parts and drill small bores first to check the alignment of bores and mounting points.

Right side

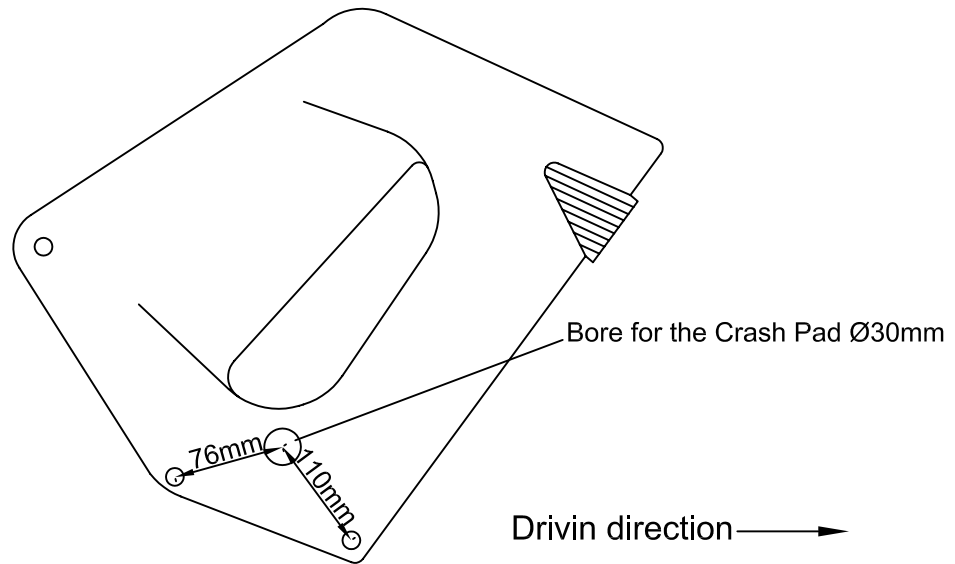

Left side

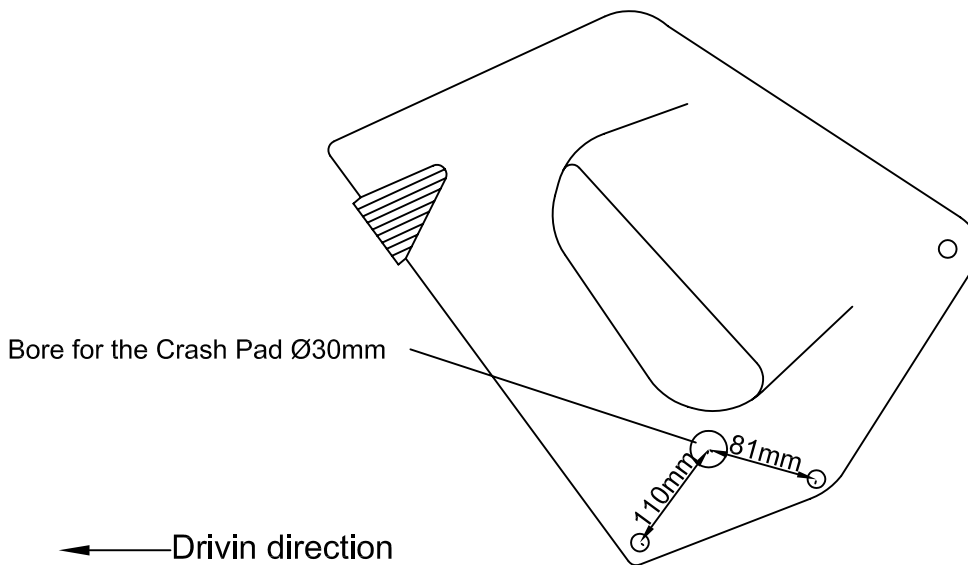

D – 47809 Krefeld

www.lsl-motorradtechnik.de

Stand: 12/06