

Important: If you are not a trained motorcycle mechanic stop now. Ask a local motorcycle shop to do the work for you.

Please take extra care!

You have to mount the crash pads one side after the other! Do not loose more then one engine mounting bolt at the same time!

The tightening torques refer to the manufacturer's instructions!

To avoid, that with high speed, the fairing parts touch the Crash Pads, use one half of the attached protector stripes for each Crash Pad and glue it on the reverse side!

Fitting of the right side:

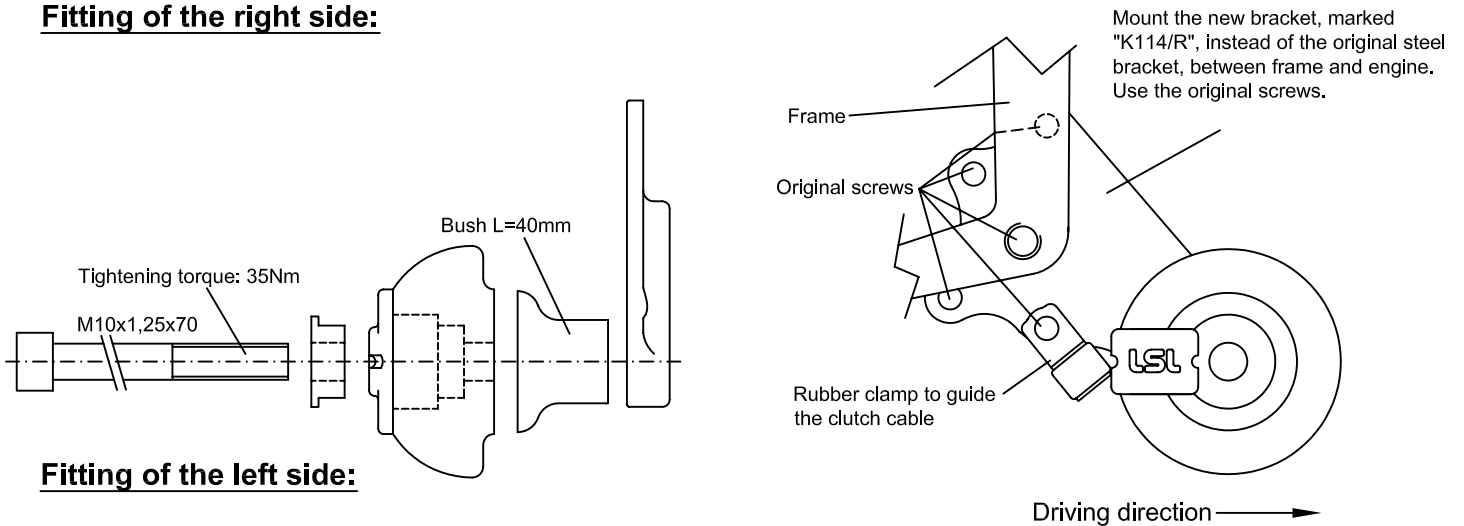

Fitting of the left side:

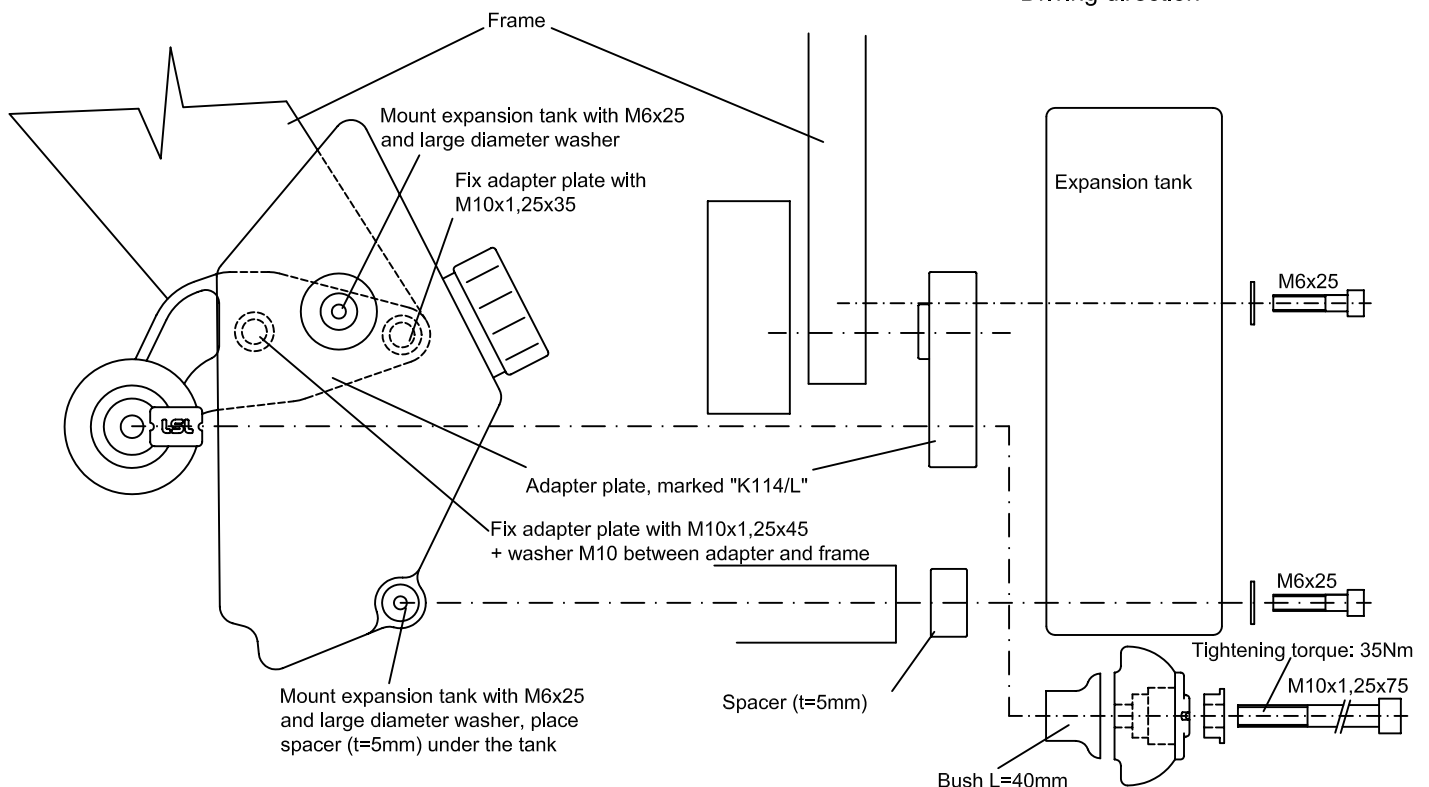

LSL-Motorradtechnik GmbH • D-47809 Krefeld

www.lsl-motorradtechnik.de

Stand: 17.11.2006

