



Anbauanleitung Fitting Instruction Notice de Montage

Artikel-Nr. / Article-No. / N° article : 550...

Produkt / Product / Produit : **Crash Pads**

Achtung! Wichtiger Montage-Hinweis. Bei Nichtbeachtung können Gesundheit und Leben gefährdet sein.



Attention! Important mounting instruction. It shows risks to your life and health.

Attention! Indication de montage importante. Le non respect des consignes peut mettre votre santé et votre vie en danger.

Wenn sie Aluminium Crash Pads montieren: Entfernen Sie die originale Kragenbuchse (1) aus den Crash Pads und verwenden Sie die Kragenbuchse (2) aus dem Montage-Kit wie abgebildet.

When you mount aluminium Crash Pads: Remove the original flange bush (1) from the Crash Pads and use the flange bush (2) delivered with the mounting kit as shown.

Pour le montage des Crash Pads en aluminium: Supprimez les douilles à embase d'origines (1) et remplacez-les par celles incluses dans le kit (2).

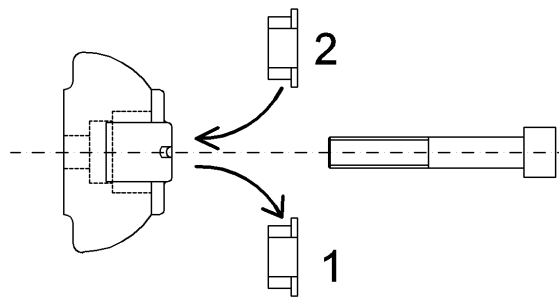

Wenn sie Kunststoff Crash Pads montieren: Entfernen Sie die originale Kragenbuchse (1) aus den Crash Pads und verwenden Sie die Kragenbuchse (2) und die Distanzbuchse (3) aus dem Montage-Kit wie abgebildet.

When you mount plastic Crash Pads: Remove the original flange bush (1) from the Crash Pads and use the flange bush (2) and the distance bush (3) delivered with the mounting kit as shown.

Pour le montage des Crash Pads en matière plastique: Supprimez les douilles à embase d'origines (1) et remplacez-les par celles incluses dans le kit (2) ainsi que l'entretoise d'écartement (3) comme indiqué ci-dessous.

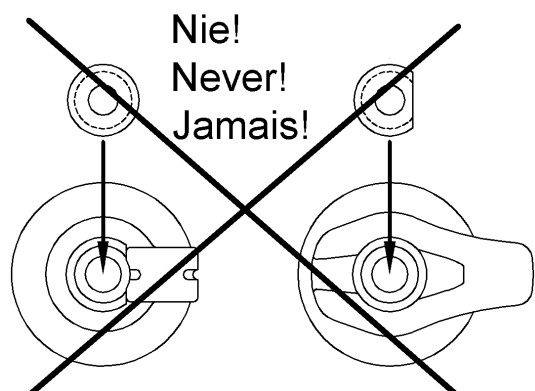
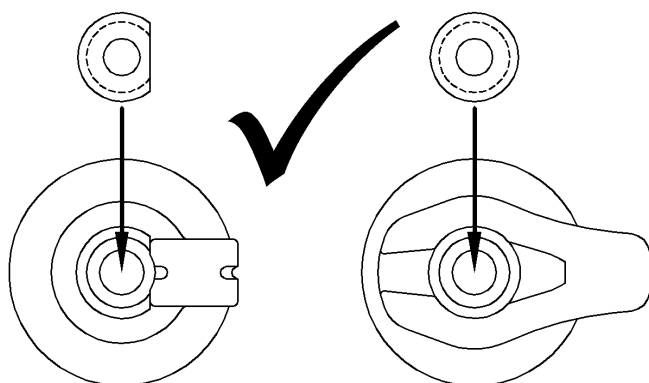
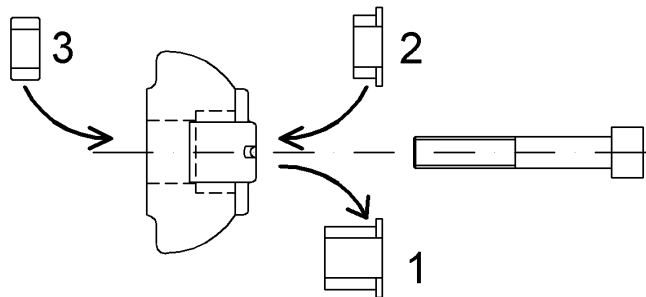

Important: If you are not a trained motorcycle mechanic, stop now. Ask a local motorcycle shop to do the work for you.

Please take extra care!

The crash pads has to be mounted one side after the other! Don't release both engine bolts!
Both fairings have to be drilled as shown at the attached drilling template! (see overleaf)

Instruction right side

1. For an exact fit of the spacer $L=34$ mm, you has to mount first the right side completely. (without fairing).
2. Fitt the clamp screw.
3. Demount the screw M12x1,25x140, bushing $L=20,5$ mm and the Crash Pad.
4. Mount the fairing and drill it. Attention: Take care on the special drilling-instruction!
5. Mount again the Crash Pad with screw and bushing.

The tightening torques refers to the vehicle manufacturers instructions!

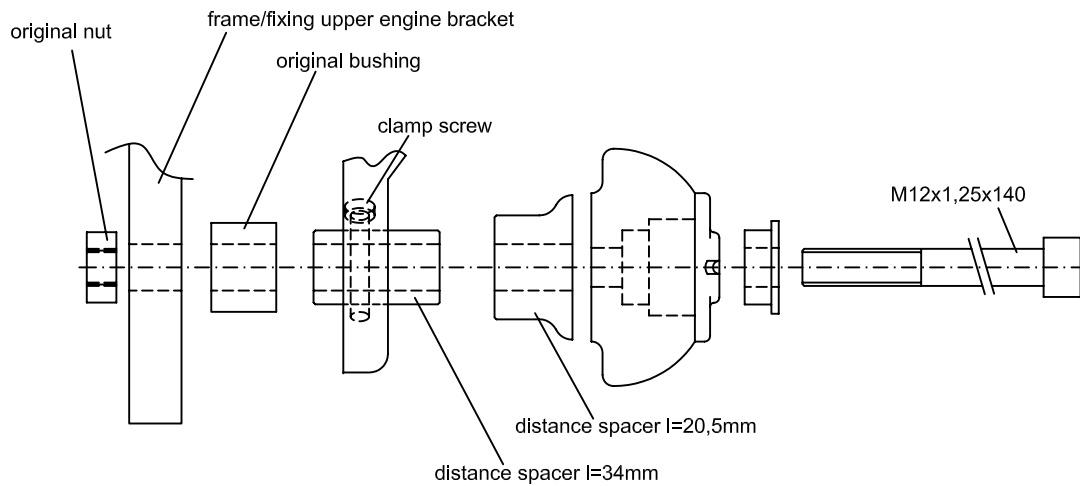

Instruction left side

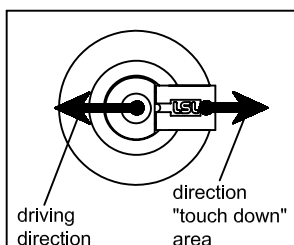
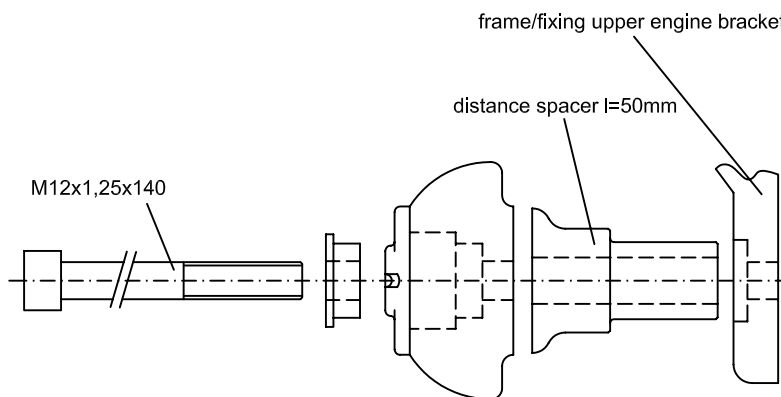

Attention: Drill first a small hole into the fairing and check, if the drill and the fixing point being align!

Fairing right side

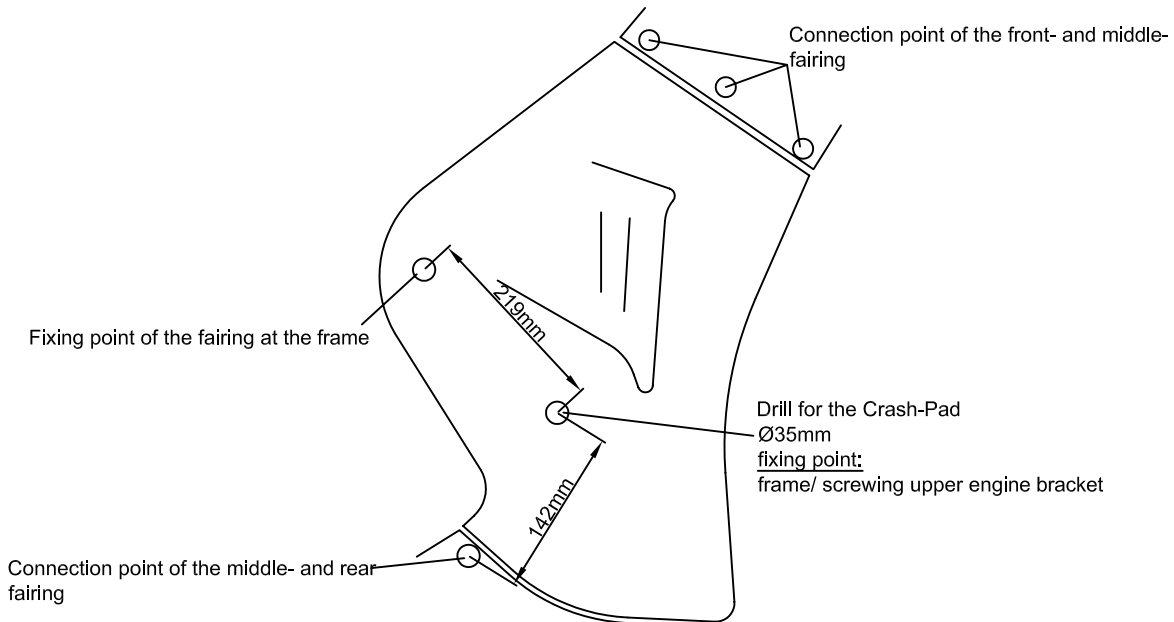

Fairing left side

