

**Important:** If you are not a trained motorcycle mechanic stop now. Ask a local motorcycle shop to do the work for you.

**Please take extra care!**

You need to mount the crash-pads one side after the other! Do not loose more than one engine mounting bolt at the same time!

The tightening torques refer to the manufacturer's instructions!

Use the attached template to drill the cowling!

**Fitting on the right side:**

(View from the rear)

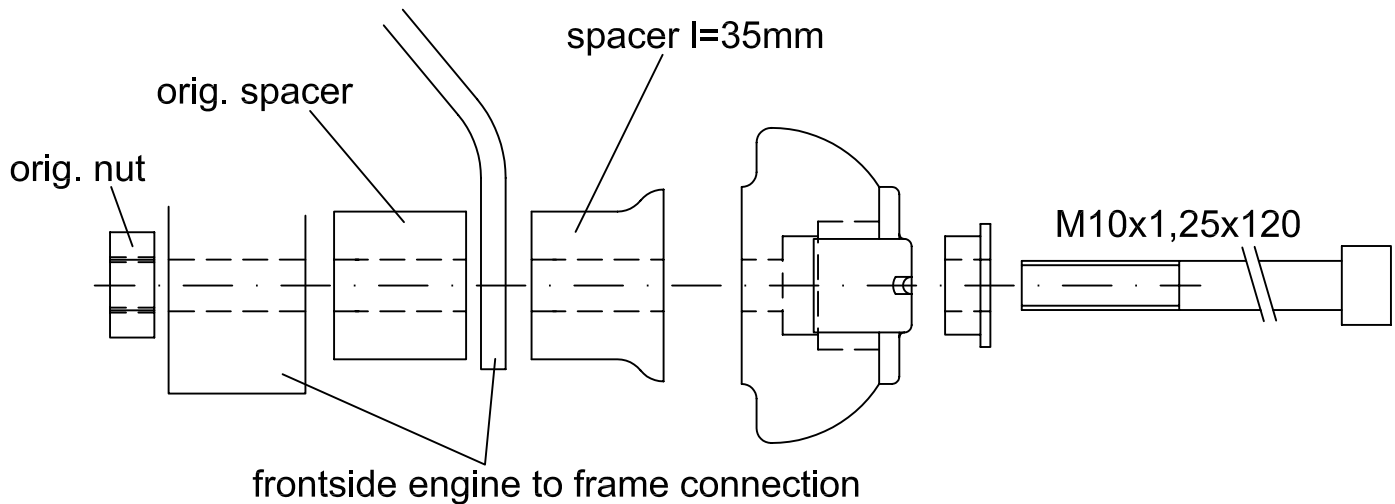

**Fitting on the left side:**

(View from the rear)

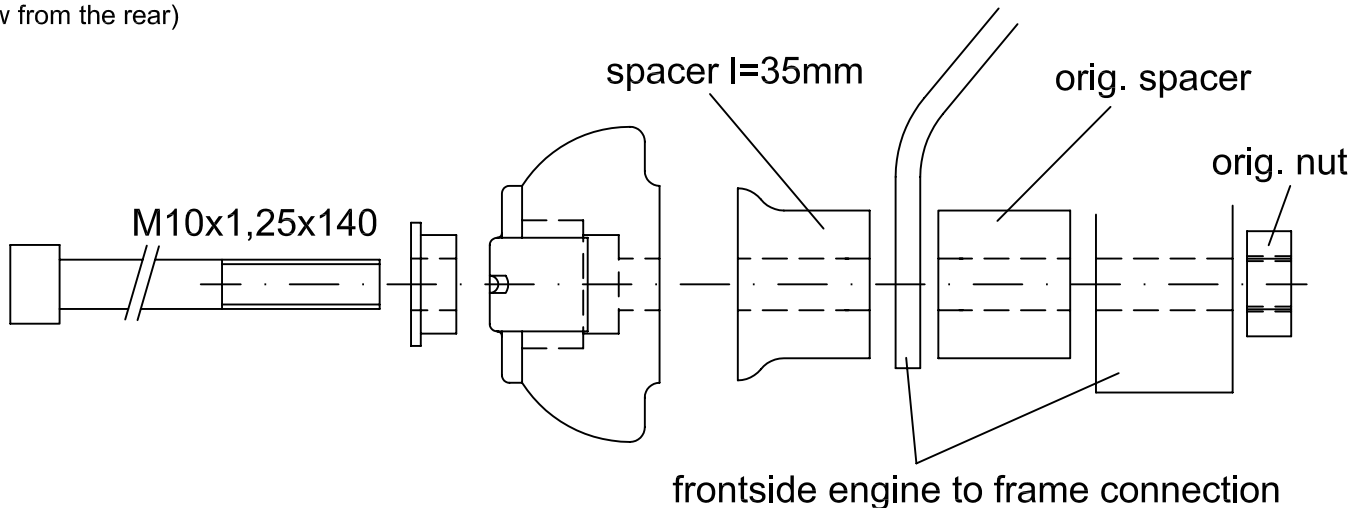

LSL-Motorradtechnik GmbH • D-47809 Krefeld

[www.lsl.eu](http://www.lsl.eu)

Rev. 00 29/01/2009

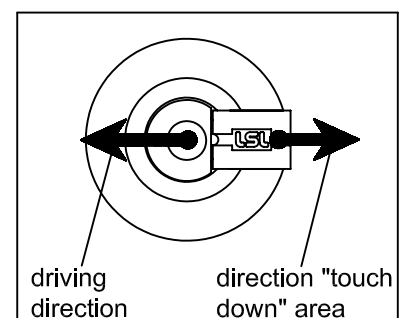

# Drilling template for Crash- Pads Honda CBR 600 F `91 - `98 Part-no.: 550H046

**Important:** At first, drill a small hole and check the alignment to the mounting point. Then enlarge the hole until the fairing doesn't scrub or jam the spacer. You can correct any mismatch in the alignment while enlarging the hole!

## cowling, right

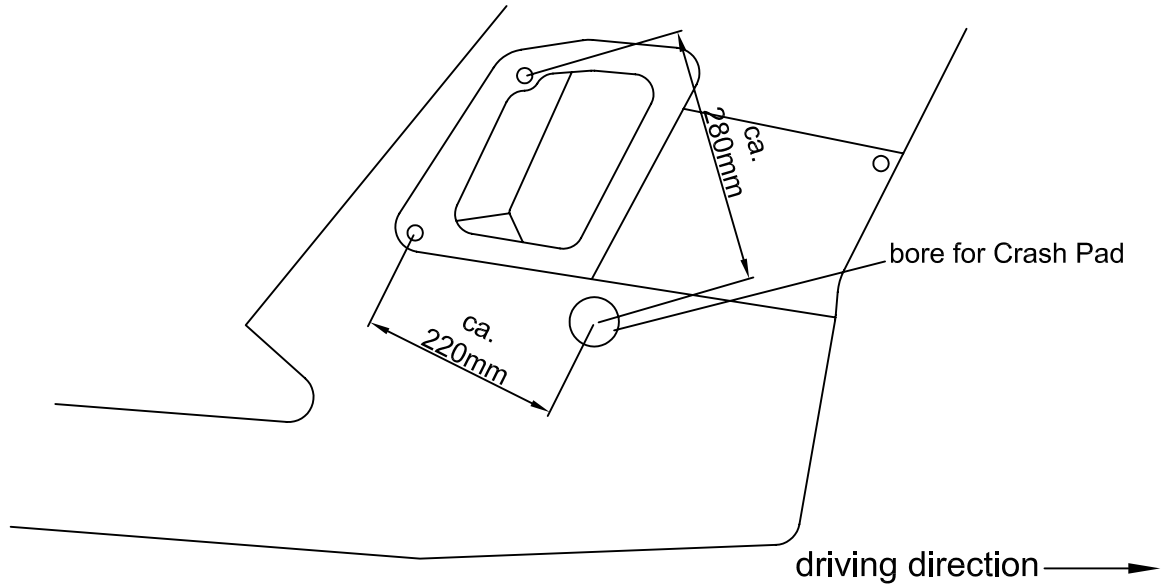

## cowling, left

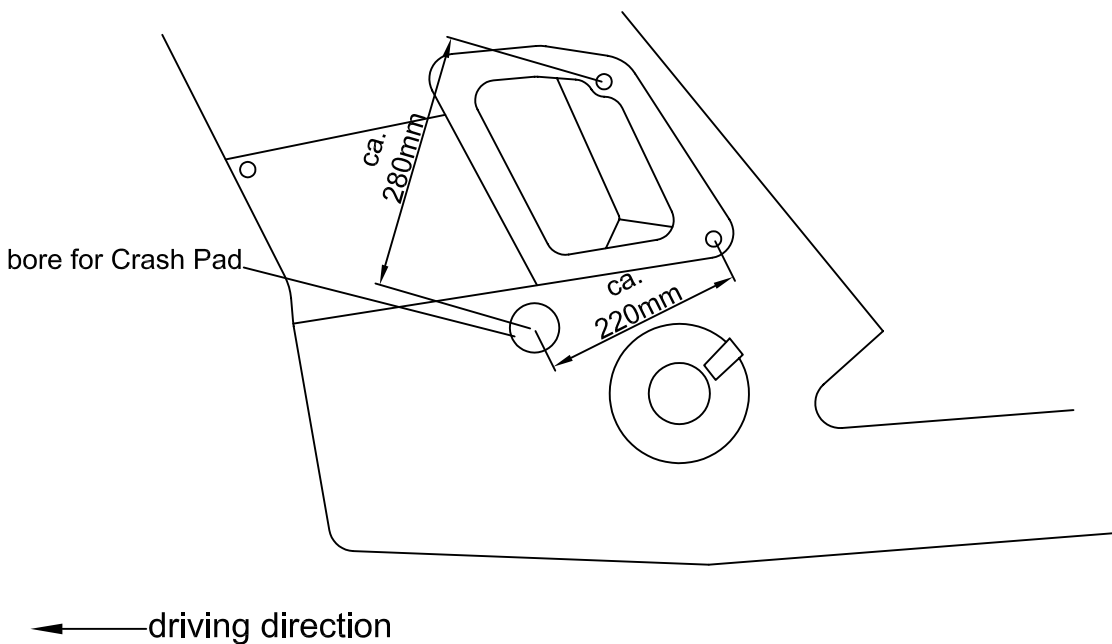

D – 47809 Krefeld

[www.lsl.eu](http://www.lsl.eu)

Rev. 00 29/01/2009